

IO-Link – Detecting

HOW IO-LINK IS REVOLUTIONIZING BINARY DETECTION OF OBJECTS

Thanks to the expanded possibilities IO-Link-capable sensors offer you in installation, diagnostics and configuring, the industrial, automated detection of objects has been raised to a new level of quality. And you will soon be able to connect binary standard sensors to the controller easily through IO-Link sensor/actuator hubs.



Reliable detection of colored labels with the IO-Link color sensor

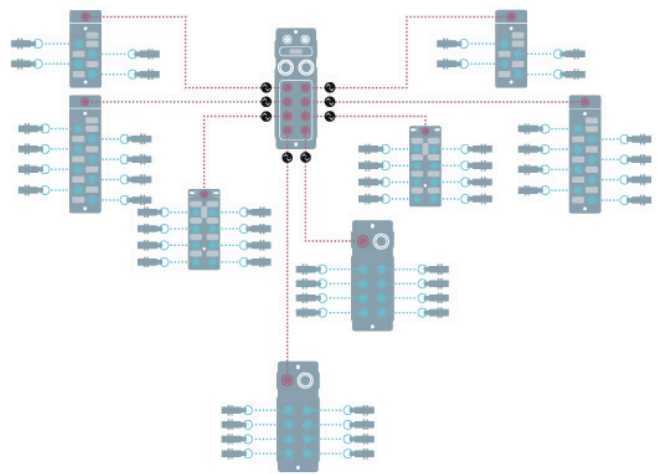

Simplified installation when connecting a variety of binary sensors through sensor/actuator hubs

Colored labels are reliably detected using an IO-Link-capable color sensor. With IO-Link you can perform startup, format and recipe changes centrally using function blocks in the controller. This saves you time and reduces the potential for errors to a minimum.

The signals from binary switching sensors can be condensed using sensor/actuator hubs and sent to the controller over IO-Link. You benefit from decentralized installation and significantly reduced control cabinet volume. Assembled standard cables are all that are needed.



IO-Link capable intelligent color sensor



Teachable inductive sensor with IO-Link and adjustable switching distance



Photoelectric sensor with adjustable background suppression over IO-Link



Sensor/actuator hub for connecting binary and/or analog sensors and actuators

A variety of IO-Link capable binary sensors are available for object detection:

- **Color sensors** – teachable over IO-Link and selectable when recipes are changed
- **Inductive sensors** – with warning message when leaving the reliable working range
- **Photoelectric sensors** – configurable background and/or foreground suppression over IO-Link

Each IO-Link sensor comes with the identification data of the manufacturer and the parameters described in the IODD (IO Device Description). You can connect up to 16 binary standard sensors to the sensor/actuator hub.